

MANIFOLD BLOCK BEFORE ASSEMBLY

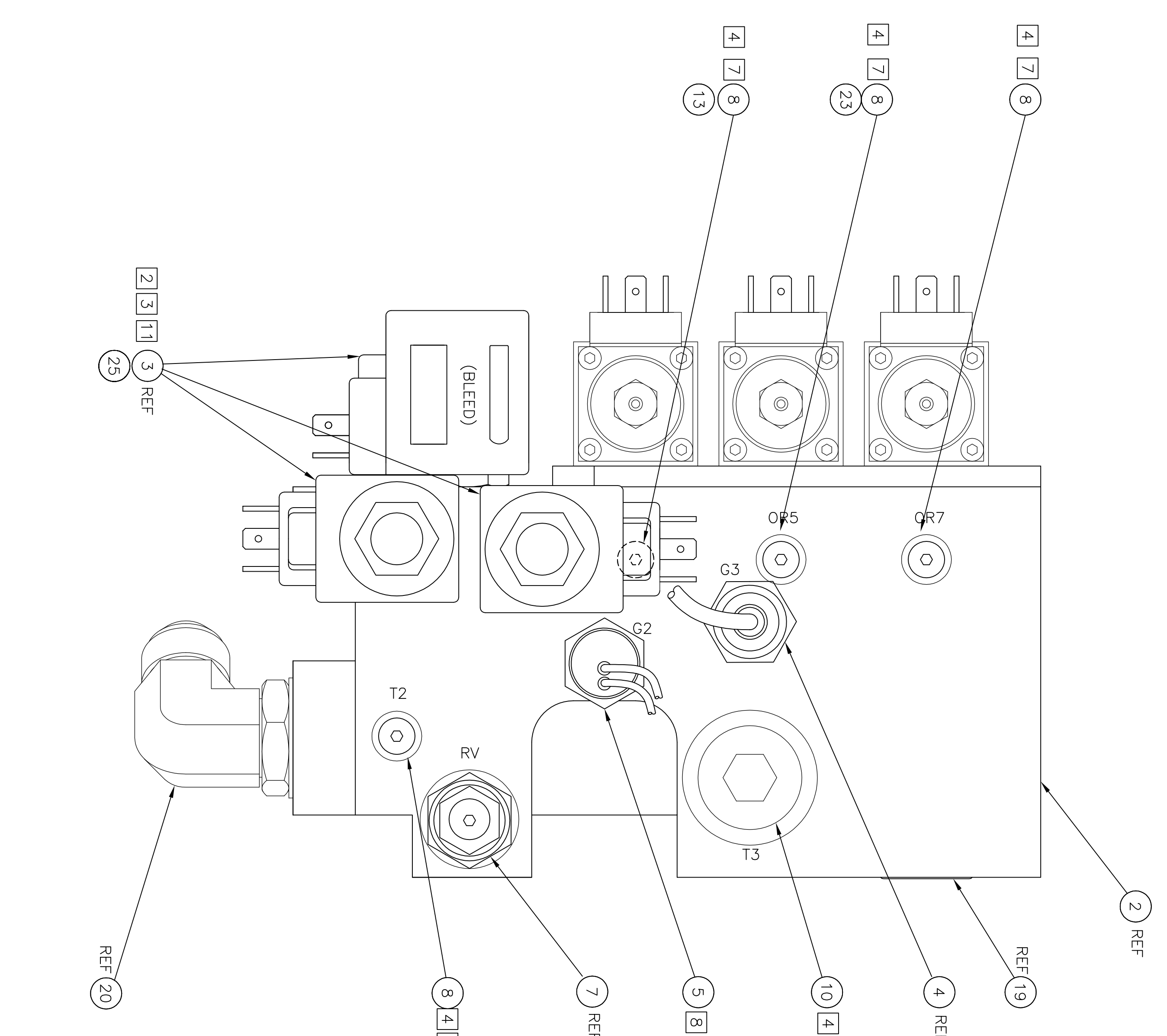
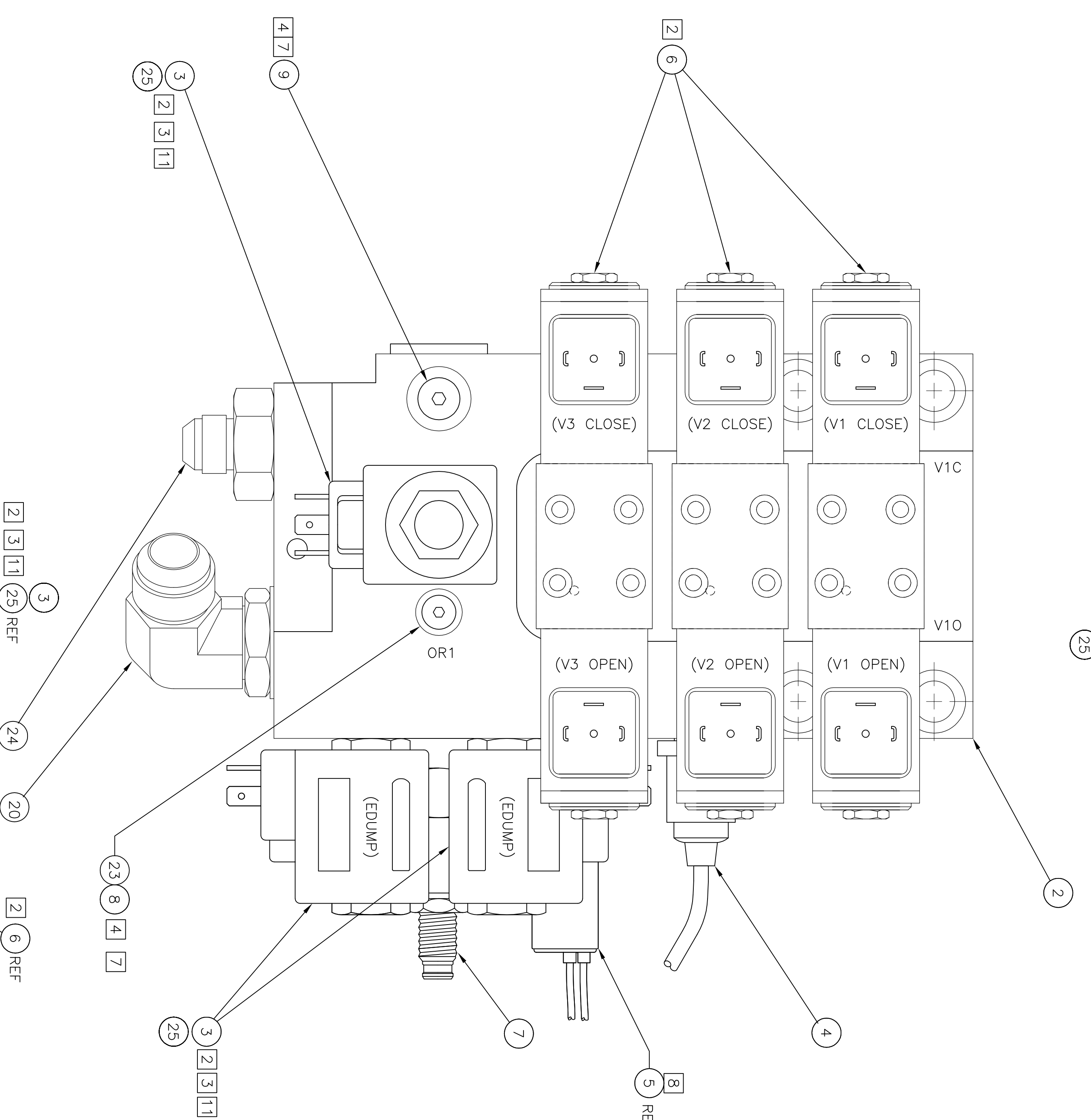
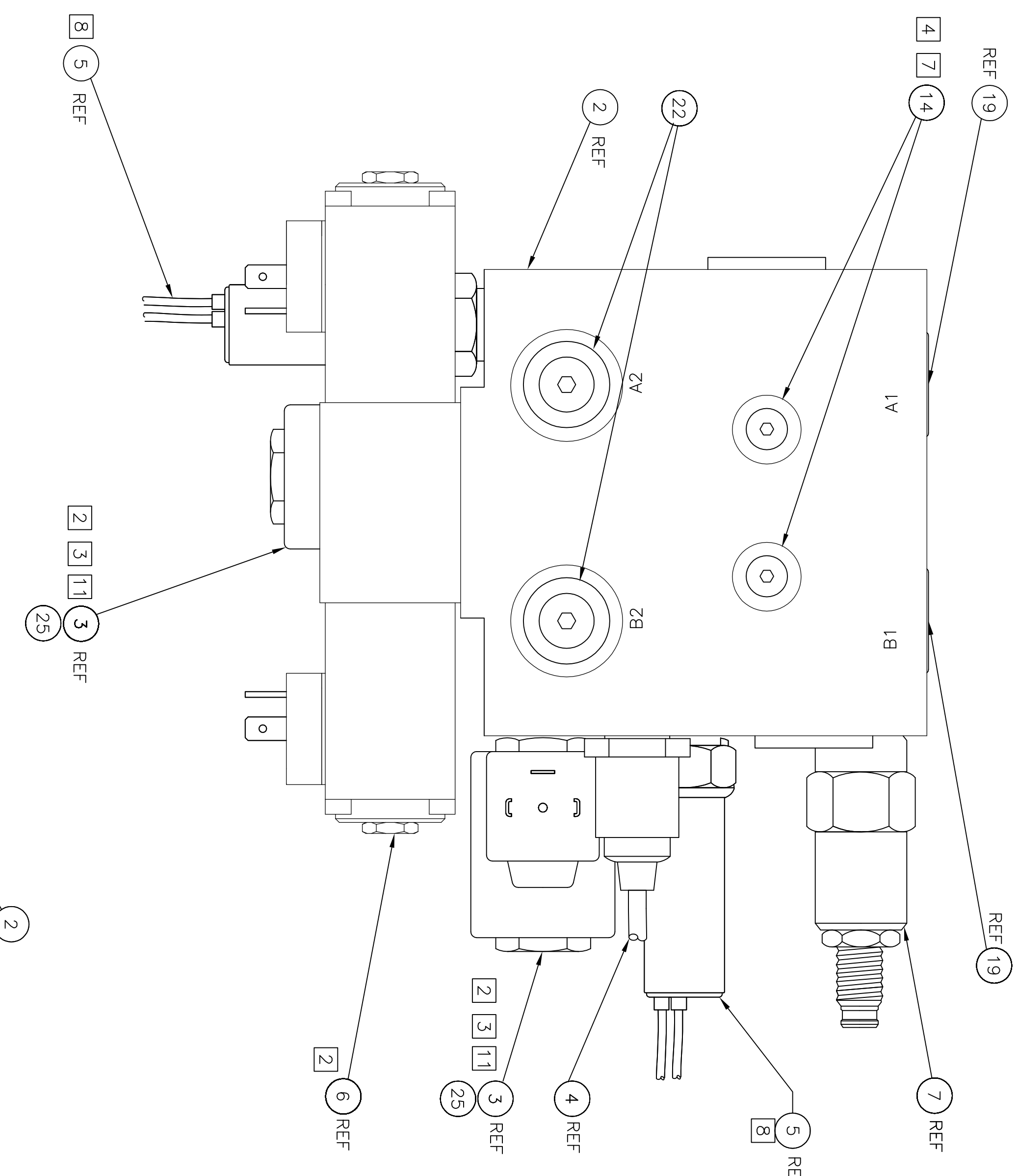
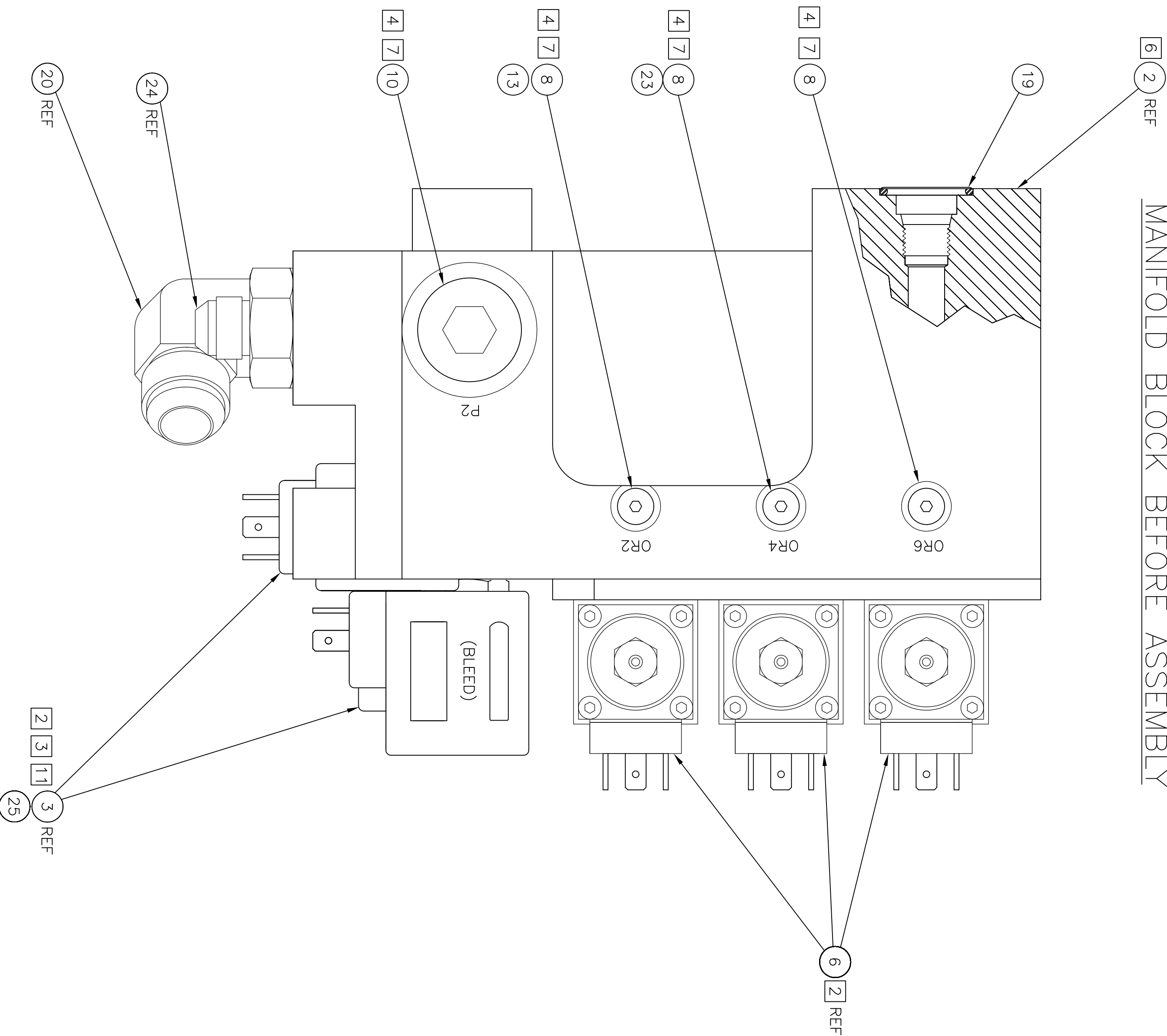

- NOTES:**
- FOR FLUSHING PROCEDURE REFER TO RETARDANT DISPENSAL SYSTEM OPERATORS MANUAL.
 - APPLY #242 LOCKTITE TO ALL COIL RETAINER NUTS.
 - 3 AND -25 ARE PURCHASED TOGETHER AS WICKERS P/N SBV11-10-0-0-24DGH AND ROTATION OF COILS MAY BE ADJUSTED ON INSTALLATION FOR BEST ROTATION.
 - ALL -8, -9, AND -10 O-RING PLUGS MUST BE INSTALLED FIRST IN -2 BLOCK. INSTALL O-RINGS FIRST AS REQUIRED.
 - ENTIRE MANIFOLD ASSEMBLY CAN BE PURCHASED FROM HYDROQUIP LESS -4 & -5 (P/N DT-1004-1002). INSTALL PLUGS IN PLACE OF -4 & -5 (P/N DT-1004-1002) TO PREVENT SURFACE MOUNTS DIRECTLY TO ACTUATOR SUPPLIED WITH -2 MANIFOLD.
 - AIR TRACTOR SWITCH P/N 82063-6, SHEET 2 IS AN ACCEPTABLE REPLACEMENT.
 - REMOVE AND DISCARD FROM DT-1004 ASSEMBLY.
 - OR SUBSTITUTE FOR -5 PRESSURE SWITCH ASSEMBLY.
 - CLEAN AND TEST MANIFOLD ASSEMBLY ACCORDING TO PS# 210 PRIOR TO INSTALLATION.
 - DELTA POWER SOLENOID VALVE ASSY (DIRECT ACTING) P/N DE-524-00-HC-24 IS AN ACCEPTABLE REPLACEMENT OR SUBSTITUTE FOR -3 AND -25 SOLENOID VALVE ASSY (PILOT OPERATED).
 - PLUG ALL PORTS AND STORE IN DUST FREE STORAGE BAG AFTER ASSEMBLY, TEST, AND CLEANING.
 - WICKERS DIRECTIONAL VALVE P/N DGV-2-2C-M-U-46-10 IS AN ACCEPTABLE REPLACEMENT OR SUBSTITUTE FOR -6 DIRECTIONAL VALVE.

QTY	DESCRIPTION	UNIT	REV
2	24DGH 3 COIL 24V DYN 43650 (WICKERS)		
2	202702-12-85 1 SAE-8 TO -12 O-RING ADAPTER (AEROCOUP)		
2	1-10-1/8-3/8 3 ORIFICE 1/4-20 UNC X 3/8" L X 80.0995" (KEEFE CONTROLS CO.)		
2	FT2138-085 2 SAE-8 O-RING PLUG (AEROCOUP)		
5	10-21 3/222-21 V ASSY (HYDROQUIP P/N DT-1004-1002)		
2	2069-12-125 1 SAE-12 90 ELBOW ADAPTER (AEROCOUP)		
2	9452K83 2 SAE-119 BUNA-N O-RING (MASTER-CARR)		
2	202702-12-85 1 SAE-8 TO -12 O-RING ADAPTER (AEROCOUP)		
2	202702-12-85 1 SAE-8 TO -12 O-RING ADAPTER (AEROCOUP)		
2	202702-8-85 1 SAE-8 ADAPTER		
2	2062-9-85 1 SAE-8 90 ELBOW ADAPTER		
2	FT2138-085 3 SAE-8 O-RING PLUG (AEROCOUP)		
2	FT2138-125 2 SAE-12 O-RING PLUG (AEROCOUP)		
2	2062-12-85 1 SAE-8 90 ELBOW TO -12 O-RING ADAPTER		
2	FT2138-045 1 SAE-4 O-RING PLUG (AEROCOUP)		
2	FT2138-045 1 SAE-4 O-RING PLUG (AEROCOUP)		
2	82063-1 1 RELIEF VALVE (GREEN) (P/N 82063-1)		
2	82063-1 1 HND. PRESS. X-DUGGER (S850-0006-01-01) (ROTTER CONTROLS)		
2	SBV11-10 3 CARTRIDGE VALVE (WICKERS)		
2	83221-1 1 MANIFOLD BLOCK (HYDROQUIP P/N 18-5507)		

NO.	DATE	BY	CHKD.	APP'D.	DESCRIPTION
1					REVISED
2					REVISED
3					REVISED
4					REVISED
5					REVISED
6					REVISED
7					REVISED
8					REVISED
9					REVISED
10					REVISED
11					REVISED
12					REVISED
13					REVISED
14					REVISED
15					REVISED
16					REVISED
17					REVISED
18					REVISED
19					REVISED
20					REVISED
21					REVISED
22					REVISED
23					REVISED
24					REVISED
25					REVISED