

- NOTE**
- NO. 30 DRILL THRU BAGGAGE COMPARTMENT WALL TO MATCH DOUBLER ATTACH WITH MS20470D4 RIVETS.
 - DRILL -3 ANGLE 287 DIA TO MATCH -16 ASSY. INSTALL HARDWARE.
 - 3/16 DIA DRILL THRU DOUBLER AND FLOOR TO MATCH MATCH HARDWARE.
 - ALTERNATE P/N FOR -16 ASSY IS TROTTER CONTROL'S P/N 1010-0040.
 - 61566-2 INSTALLATION MAY RETROFIT BACK TO S/N 0001.

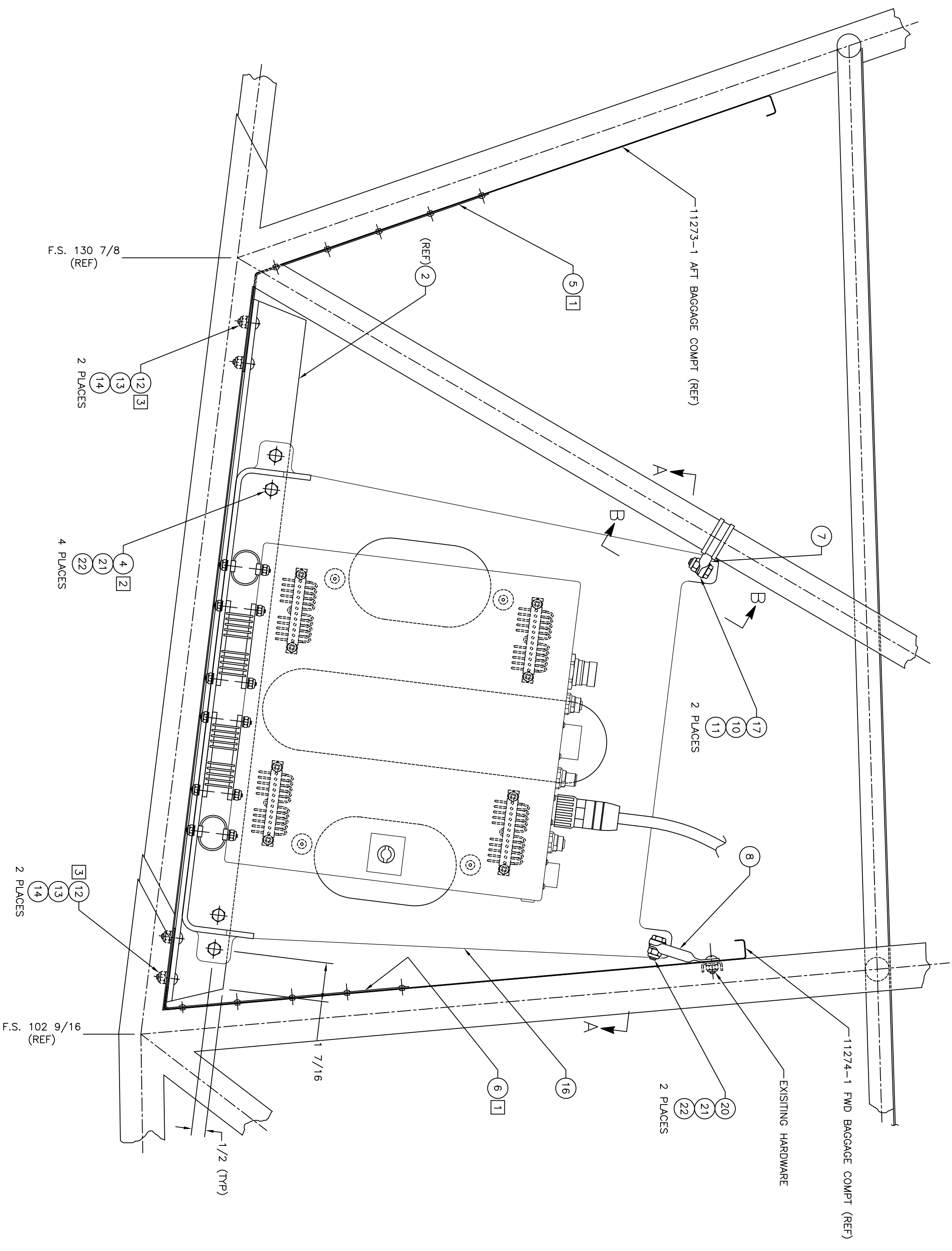
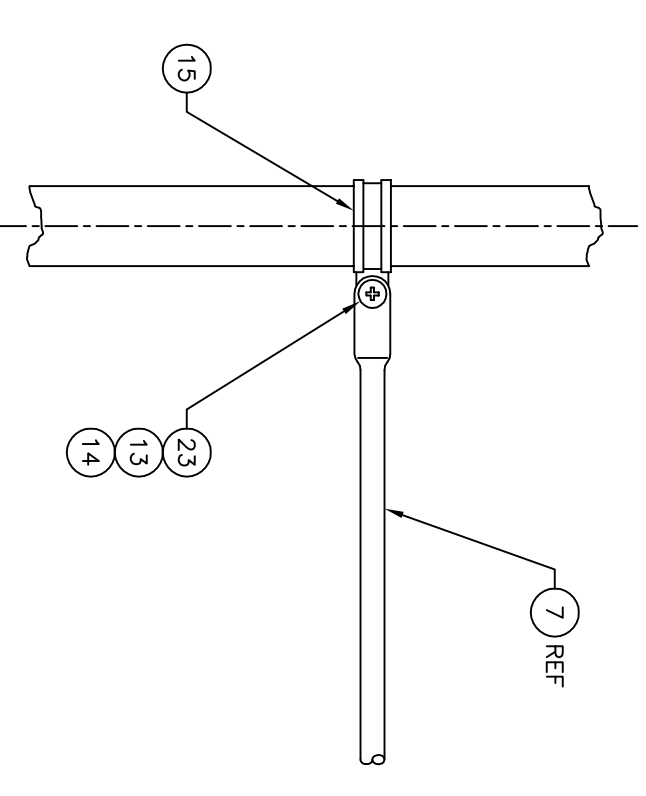
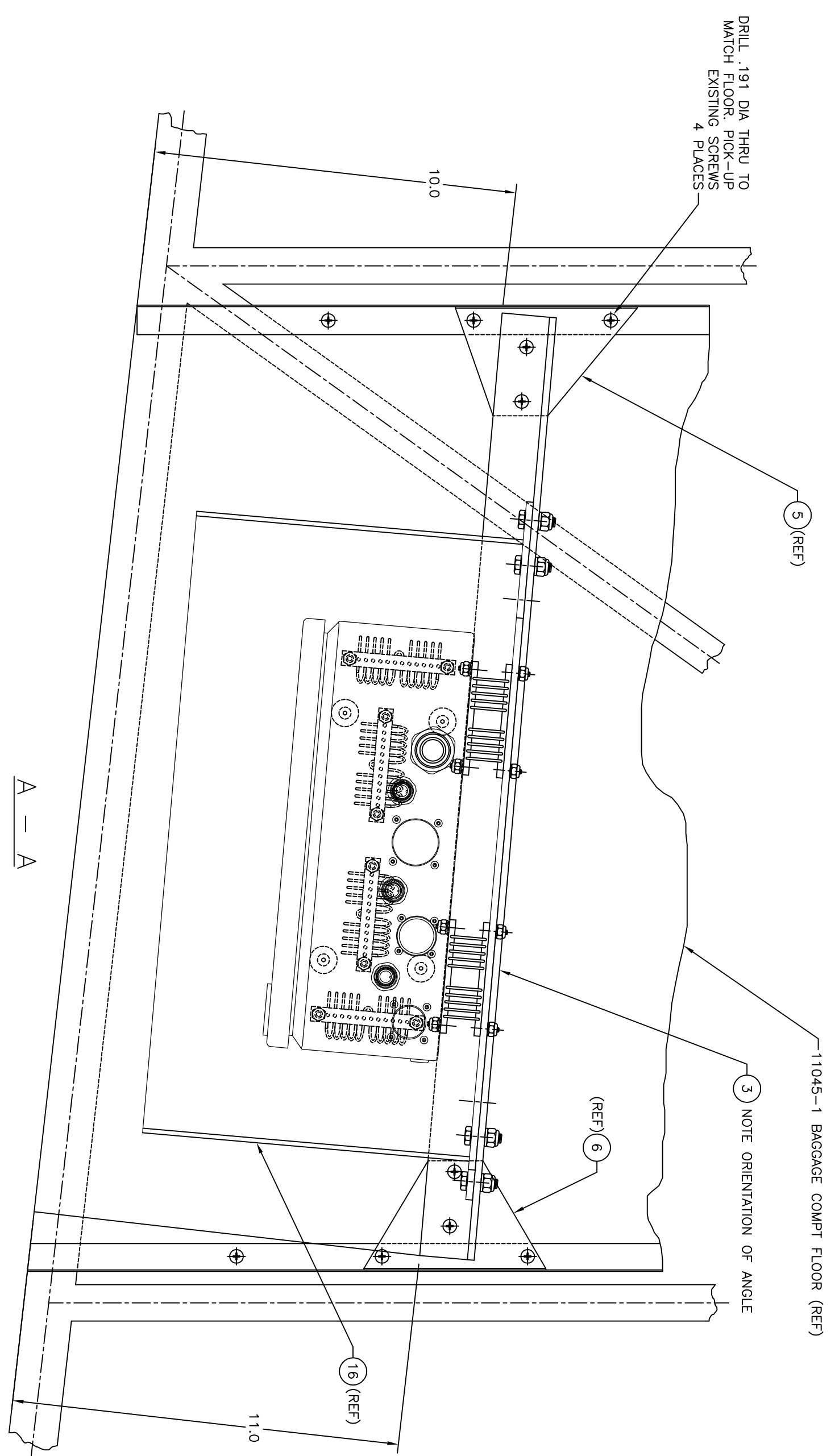

QTY	ITEM NO.	DESCRIPTION	UNIT	SCALE	DATE	BY	CHK
1	80015-5	1 SCREW					
6	AN365-428	6 NUT					
6	AN960-416	6 WASHER					
2	AN4-6A	2 BOLT					
2	AN44-5A	2 EYEBOLT					
1	81572-1	1 ASSY - RELAY BOX					
5	MS20470D4	5 CLAMP					
5	AN960-10	5 WASHER					
4	90015-7	4 SCREW					
2	AN365-524	2 NUT					
2	AN960-516	2 WASHER					
1	61348-1	1 BRACE					
1	80522-3	1 BRACE					
1	80521-1	1 DOUBLER					
4	AN4-7A	4 BOLT					
1	60517-1	1 ANGLE					
2	61566-2	2 INSTALLATION					
1	802F	1 SEF SHEET 1 FOR 1002					