

<b>Trotter Controls, Inc. FT. WORTH, TEXAS</b>	<b>TECHNICAL PAPER</b>		NUMBER <b>1002</b>
	<b>REPORT ORDER</b>		MODEL Fire Bombers
TITLE GEN II FRDS - SYSTEM DESCRIPTION	BY V. Trotter	CHK'D CG	SERIAL ALL FIREBOMBERS
	DATE 2/19/2009		PAGE 1
			OF 30

**I. REFERENCE :**

- [1] Snow Engineering Co. Drawing 80504 Sheet 21, "Hydraulic Schematic"
- [2] Snow Engineering Co. Drawing 60445, Sheet 21 "Control Logic Flow Chart"
- [3] Snow Engineering Co. Drawing 80577, Sheet 21 "Hydraulic System Installation"
- [4] Snow Engineering Co. Drawing 83056, "Installation - Gatebox Actuator"
- [5] Snow Engineering Co. Report 1108, "Hazard Minimization - Manual Fire Gate Emergency Dump Enhancement"
- [6] Snow Engineering Co. Drawing 60441, Sheet 21 "Control System Wiring Schematic"
- [7] Snow Engineering Co. Report 1598, "Component Data - Fire Retardant Dispersal System"
- [8] Snow Engineering Co. Drawing 83224, "Assembly - Hydraulic Pump"
- [9] Snow Engineering Co. Drawing 83222, Sheet 21, "Hydraulic Manifold Assy - FIRE GATE"
- [10] Snow Engineering Co. Drawing 71807, "Installation - System - Emergency Dump"
- [11] Snow Engineering Co. Drawing 80866, "Assy - Hopper Handle"
- [12] Snow Engineering Co. Drawing 71060, Sheet 2, "Pneumatic EDUMP Schematic"
- [13] Snow Engineering Co. Drawing 83118, "Float Installation - Hopper"
- [14] Attachments:  
Attachment 1 - FRDS overview diagram  
Attachment 2 - Position control loop block diagram

<b>Trotter Controls, Inc. FT. WORTH, TEXAS</b>	<b>TECHNICAL PAPER</b>		NUMBER <b>1002</b>
	<b>REPORT ORDER</b>	<input checked="" type="checkbox"/>	MODEL Fire Bombers
TITLE GEN II FRDS - SYSTEM DESCRIPTION	BY V. Trotter	CHK'D CG	SERIAL ALL FIREBOMBERS
	DATE 2/19/2009		PAGE 2
			OF 30

**II. PURPOSE:**

The purpose of this report is to briefly describe the components and operation of the Fire Retardant Dispersal System (FRDS) controls and hydraulics.

**III. APPLICATION OF SYSTEM:**

The electrical control system works in conjunction with the hydraulics system to control the position of the gatebox doors in order to meter the flow of water in a continuous fashion from the aircraft retardant tanks.

A typical retardant release takes a minimum of approximately 0.5 seconds up to a maximum of about 10 seconds.

The system is in a standby state until the pilot initiates a release. The system then controls the retardant release via the position of the gatebox doors, recharges the hydraulic accumulators and returns to the standby mode.

**IV. SYSTEM COMPONENT DESCRIPTION:**

The various components used in the system are described in the following sections. Note that manufacturer's literature for most of the items can be found included in Reference [7].

ASSY, Pilot Interface:

The pilot interface shown on 60441, sheet 21, and Figure 6 of this report is used to provide the logic necessary for the following functions:

- The main system microprocessor used to control all logic functions for the system when in AUTO or TIMER mode.
- Monitor analog and digital sensor inputs
- Monitor diagnostic inputs and display system status
- Provides power and control to remote hopper contents gages
- Provides messages and status to the pilot
- Accepts inputs from pilot switches

<b>Trotter Controls, Inc.</b> <b>FT. WORTH, TEXAS</b>	<b>TECHNICAL PAPER</b>		NUMBER <b>1002</b>
	<b>REPORT ORDER</b>	<input checked="" type="checkbox"/>	MODEL Fire Bombers
TITLE GEN II FRDS - SYSTEM DESCRIPTION	BY V. Trotter	CHK'D CG	SERIAL ALL FIREBOMBERS
	DATE 2/19/2009		PAGE 3
			OF 30

- Provides control of the system when in AUTO or TIMER mode
  - o Performs calculations for desired door angle based on various sensor inputs
  - o Powers relay coils as required to operate various valves in the system as well as the hydraulic pump motor
  - o Performs passive diagnostics and system self tests
- Contains the simple microprocessor ( $\mu$ P) based AUTO SALVO system that will isolate the primary system and open the gatebox doors in the event that the primary system is unable to open the doors. This is discussed in more detail later.
- Contains an accelerometer used to sense the vertical acceleration of the aircraft.

The operational functionality and performance of the pilot interface is identical to the operation of the existing production FRDS system except for additional diagnostic and self test functions that are available to the pilot.

External Hopper Contents Gages:

The system uses two remote vacuum fluorescent displays (VFD's) or LED displays to display the gallons of retardant present in the retardant hopper to the retardant loading crew located outside of the aircraft. The connections to the pilot interface are shown in Reference [6].

ASSY, Enclosure - FRDS Relay:

The relay enclosure shown on drawing 60441, sheet 21 contains relays and other devices required to control the hydraulic valves during system operation.

The relay enclosure provides the following functions:

- Accepts signals from the pilot interface to operate various relays when in AUTO or TIMER mode
- Provides voltage regulation for various sensors
- Connects to and provides power to the various valves in the system

<b>Trotter Controls, Inc. FT. WORTH, TEXAS</b>	<b>TECHNICAL PAPER</b>		NUMBER <b>1002</b>
	<b>REPORT ORDER</b>	<input checked="" type="checkbox"/>	MODEL Fire Bombers
TITLE GEN II FRDS - SYSTEM DESCRIPTION	BY V. Trotter	CHK'D CG	SERIAL ALL FIREBOMBERS
	DATE 2/19/2009		PAGE 4
			OF 30

- Provides a fully electro-mechanical (EM) system that enables the following functionality when in EM mode:
  - Allows electro-mechanical operation by bypassing all functions in the pilot interface except for the switch inputs which directly control the relay coils of the electro-mechanical system (no software)
  - Controls the valves to manually open or close the doors using only relays and switches
  - Controls the hydraulic pump using an independent pressure switch (no software)
- Supervises the pilot interface microprocessor(s) and opens the gatebox doors if the doors fail to open as expected (no software). This is handled by the Supervisory Salvo (Auto Salvo) and the secondary EM SALVO (Man Salvo) in succession. This backup system is discussed in more detail later.

System Sensors:

The system utilizes the following sensors for system control when in the AUTO or TIMER modes of operation.

- Pressure Sensor (83222-4) ~ This sensor outputs a voltage proportional to system hydraulic pressure for use by the microprocessor controlled primary system when the system is in AUTO or TIMER mode. See hydraulics components.
- Pressure Switch (83222-5) ~ This pressure switch controls the hydraulic pump motor when the system is in Electro-Mechanical (EM) mode. See hydraulics components.
- Hopper Contents Sensor (83118-12, 83118-24) ~ This sensor outputs a voltage proportional to the rotary position of the hopper float shaft. The microprocessor calculates the gallons in the hopper based on this voltage for use during retardant delivery and for display to the pilot.

<b>Trotter Controls, Inc. FT. WORTH, TEXAS</b>	<b>TECHNICAL PAPER</b>		NUMBER <b>1002</b>
	<b>REPORT ORDER</b>		MODEL
TITLE GEN II FRDS - SYSTEM DESCRIPTION	BY	CHK'D	Fire Bombers
	V. Trotter	CG	SERIAL
	DATE	2/19/2009	ALL FIREBOMBERS
			PAGE OF
			5 30

- Gatebox Angle Sensor (83056-54, 83056-55) ~ This sensor outputs an analog voltage that is proportional to the rotary position of the gatebox hydraulic actuator. The microprocessor uses this signal when controlling the gatebox door angle in AUTO mode only.
- Gatebox Proximity Sensors (83056-56) ~ Two inductive proximity sensors are monitored to sense when the gatebox doors are closed in AUTO mode. One of these sensors is also used by the microprocessor controlled AUTO SALVO system. The other sensor is used by the redundant electro-mechanical MAN SALVO system. Each sensors function is identical. Two sensors are provided for redundancy in AUTO mode and each sensor provides independent information to the salvo systems.
- Accelerometer - An accelerometer is contained within the pilot interface. This sensor provides the control system with voltage proportional to the acceleration of the aircraft. This is used by the computer for flow rate / door angle calculations in AUTO mode only.

Hydraulic Components:

The hydraulic system is composed of several major components. Please refer to drawing 80504, Sheet 21 (Hydraulic Schematic). The motor/pump combination, solenoid valves, directional valves, accumulators, pressure switch, pressure sensor, oil filters, rotary actuator, and fluid reservoir are used during normal operation of the system. The components discussed below are numbered for cross reference to the Hydraulic Schematic (drawing 80504, Sheet 21).

The basic system is briefly described below (please refer to drawing 60445, Sheet 21 for a logic diagram of the hydraulics pressure system and emergency dump hardwired logic).

<b>Trotter Controls, Inc. FT. WORTH, TEXAS</b>	<b>TECHNICAL PAPER</b>		NUMBER <b>1002</b>
	<b>REPORT ORDER</b>	<input checked="" type="checkbox"/>	MODEL Fire Bombers
TITLE GEN II FRDS - SYSTEM DESCRIPTION	BY V. Trotter	CHK'D CG	SERIAL ALL FIREBOMBERS
	DATE 2/19/2009		PAGE 6
			OF 30

Hydraulic Reservoir:

The 83180-1 tank shown as item 11 on drawing 80577 is the hydraulic fluid reservoir having a capacity of 3.61 gallons. The reservoir is vented directly to atmosphere through a filtered breather to allow for variation in the fluid level within the tank.

The reservoir supplies hydraulic oil to the low-pressure filter and pump inlet and receives low-pressure return oil from the 83222 hydraulic manifold assembly.

The volume of fluid in the reservoir can vary by approximately 0.5~0.6 gallons due to the compliance of the nitrogen accumulator bladders as the system is pressurized from zero PSI to 3000 PSI.

Low Pressure Filter:

The low pressure filter (80577-52) is a spin on type hydraulic oil filter. The 10 micron rated filter has a flow rating of 50 GPM.

The low pressure hydraulic filter is placed between the reservoir and the hydraulic pump to capture particles from the reservoir before they reach the precision hydraulic gear pump.

Since the hydraulic pump delivers a maximum flow rate of only 0.83 GPM, the filter under normal operating conditions will not cause pump cavitation during the recommended lubrication service interval.

Motor/Pump Combination:

The pump assembly consists of a 24 volt permanent magnet DC motor coupled to a hydraulic gear pump. The hydraulic pump delivers approximately 0.83 GPM at zero pressure and 0.71 GPM at 3000 PSI. The 83224 pump assembly is shown installed in drawing 80577, sheet 21.

The motor/pump combination (83224-1) is used to maintain the pressure in the accumulators at the nominal working pressure of 3000 PSI. The pump is able to pressurize the accumulators from zero PSI to 3000 PSI in approximately 45 to 60 seconds.

<b>Trotter Controls, Inc.</b> <b>FT. WORTH, TEXAS</b>	<b>TECHNICAL PAPER</b>		NUMBER <b>1002</b>
	<b>REPORT ORDER</b>	<input checked="" type="checkbox"/>	MODEL Fire Bombers
TITLE GEN II FRDS - SYSTEM DESCRIPTION	BY V. Trotter	CHK'D CG	SERIAL ALL FIREBOMBERS
	DATE 2/19/2009		PAGE <b>7</b> OF <b>30</b>

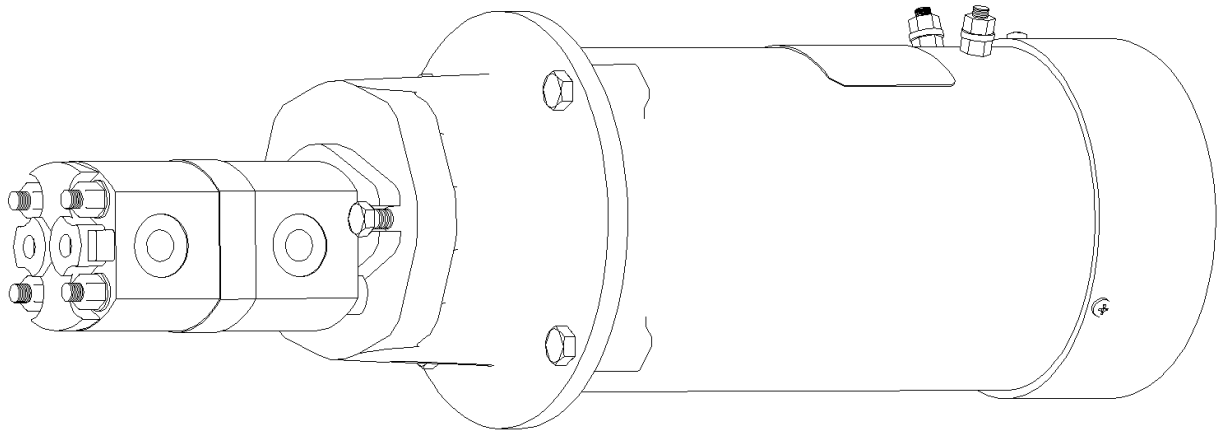

**Figure 1 ~ Hydraulic pump assembly.**

The pump motor relay shown on 60441, sheet 21 is controlled in one of two ways:

- In AUTO or TIMER mode, the pilot interface reads the analog pressure sensor (83222-4) and controls the pump as required to maintain the pressure between 2750 and 3000 PSI.
- In Electro-Mechanical (EM) mode, the (83222-5) pressure switch controls the pump motor relay directly to maintain system pressure between approximately 2780 and 3000 PSI.

**Reverse Flow Check Valves:**

Two check valves are used on the dual outputs of the hydraulic pump head to prevent oil from leaking from the inlet of the pump head to the outlet when the pump motor is not running.

Dual check valves are used to isolate the two independent gear sets in the pump heads from one another on the pump's output side for added reliability.

The check valves used are standard reverse flow check valves that will allow oil to flow in one direction only and have been used in production for many years.

<b>Trotter Controls, Inc. FT. WORTH, TEXAS</b>	<b>TECHNICAL PAPER</b>		NUMBER <b>1002</b>
	<b>REPORT ORDER</b>	<input checked="" type="checkbox"/>	MODEL Fire Bombers
TITLE GEN II FRDS - SYSTEM DESCRIPTION	BY V. Trotter	CHK'D CG	SERIAL ALL FIREBOMBERS
	DATE 2/19/2009		PAGE 8
			OF 30

Accumulators:

The two hydraulic accumulators are bladder style units that are pre-charged with nitrogen to 1650 PSI. Compression of the nitrogen filled bladder by the hydraulic fluid is used to store fluid power for use during system operation. The nominal size of each of the two accumulators is 1 gallon. For an initial oil pressure of 3000 PSI, each accumulator will deliver approximately 58 cubic inches (0.25 gallons) of oil at high flow rates.

The two parallel connected accumulators are able to provide up to 0.5 gallons of pressurized oil at peak flow rates of up to 30 GPM before system pressure reaches the minimum design pressure of 1830 PSI.

The accumulators (80577-61) are used to store hydraulic fluid power when the system is in the standby state and discharge high flow rates of fluid when the gatebox doors are operated. This allows the relatively low flow rate/low power hydraulic pump to be used in a system that requires high flow rates for very short time intervals. The accumulator also compensates for any expansion of the fluid in the system due to the compliance of the nitrogen.

Pressure Relief Valve:

A fast acting high quality mechanical pressure relief valve (83222-7) is included in the hydraulic manifold to relieve excess hydraulic pressure developed within the system.

Typically this relief valve is set to 3400 PSI. Any pressure in excess of 3400 PSI is dumped directly back to the low pressure reservoir.

During normal operation, this valve does not pass flow and is included as a redundant pressure limiting mechanism.

Pressure Switch:

The pressure switch (83222-5) is normally closed at 0 PSI and is set to open at 3000 PSI.

<b>Trotter Controls, Inc. FT. WORTH, TEXAS</b>	<b>TECHNICAL PAPER</b>		NUMBER <b>1002</b>
	<b>REPORT ORDER</b>	<input checked="" type="checkbox"/>	MODEL Fire Bombers
TITLE GEN II FRDS - SYSTEM DESCRIPTION	BY V. Trotter	CHK'D CG	SERIAL ALL FIREBOMBERS
	DATE 2/19/2009		PAGE 9
			OF 30

The pressure switch contacts are closed at pressures lower than 2780 PSI, energizing the pump relay and causing the pump to build pressure.

The pressure switch is set to de-energize the pump relay contacts at 3000 PSI, thus limiting the maximum pressure for the system.

Note that the pressure switch is used by the electro-mechanical system only. The automatic system utilizes input from an analog pressure transducer to monitor and control system pressure.

**Hydraulic Pressure Transducer:**

The hydraulic pressure transducer (83222-4) is a stainless steel 5000 PSIG (15,000 PSI burst rating) pressure sensor that outputs a voltage proportional to the pressure at the sensing port.

The microprocessor monitors the pressure sensor in all modes of operation. Input from the pressure sensor is used to control the hydraulic pump relay only when the system is in AUTO and TIMER mode to maintain the system pressure between 2750 PSI and 3000 PSI.

**High Pressure filter:**

The high pressure filter is rated at 3 microns having a pressure drop of only 26 PSID at a flow rate of 30 GPM. The filter has a built in valve that allows oil to bypass the filter element if the pressure drop across the element exceeds 50 PSID.

The high pressure filter (80577-62) is placed between the hydraulic pump and the accumulator to avoid contamination of the valves and actuator due to particles generated in the pump head.

Since the filter passes a maximum flow rate of 0.83 GPM from the hydraulic pump, the filter will not clog under normal operating conditions within the lubrication service interval.

<b>Trotter Controls, Inc.</b> <b>FT. WORTH, TEXAS</b>	<b>TECHNICAL PAPER</b>		NUMBER <b>1002</b>
	<b>REPORT ORDER</b>	<input checked="" type="checkbox"/>	MODEL Fire Bombers
TITLE GEN II FRDS - SYSTEM DESCRIPTION	BY V. Trotter	CHK'D CG	SERIAL ALL FIREBOMBERS
	DATE 2/19/2009		PAGE 10
			OF 30

Hydraulic Manifold:

To minimize the potential for leakage, increase reliability, and reduce system weight, a hydraulic manifold is incorporated in the system to mount and plumb the various valves, orifices, pressure sensor, and pressure switch.

The manifold is bolted directly to the rotary actuator via its O-RING ports.

The manifold assembly is detailed in 83222, sheet 21 and is shown in Figure 2 below.

<b>Trotter Controls, Inc.</b> <b>FT. WORTH, TEXAS</b>	<b>TECHNICAL PAPER</b>		NUMBER <b>1002</b>	
	<b>REPORT ORDER</b>		<input checked="" type="checkbox"/>	
TITLE GEN II FRDS - SYSTEM DESCRIPTION	BY V. Trotter	CHK'D CG	MODEL Fire Bombers	
	DATE 2/19/2009		SERIAL ALL FIREBOMBERS	
			PAGE 11 OF 30	

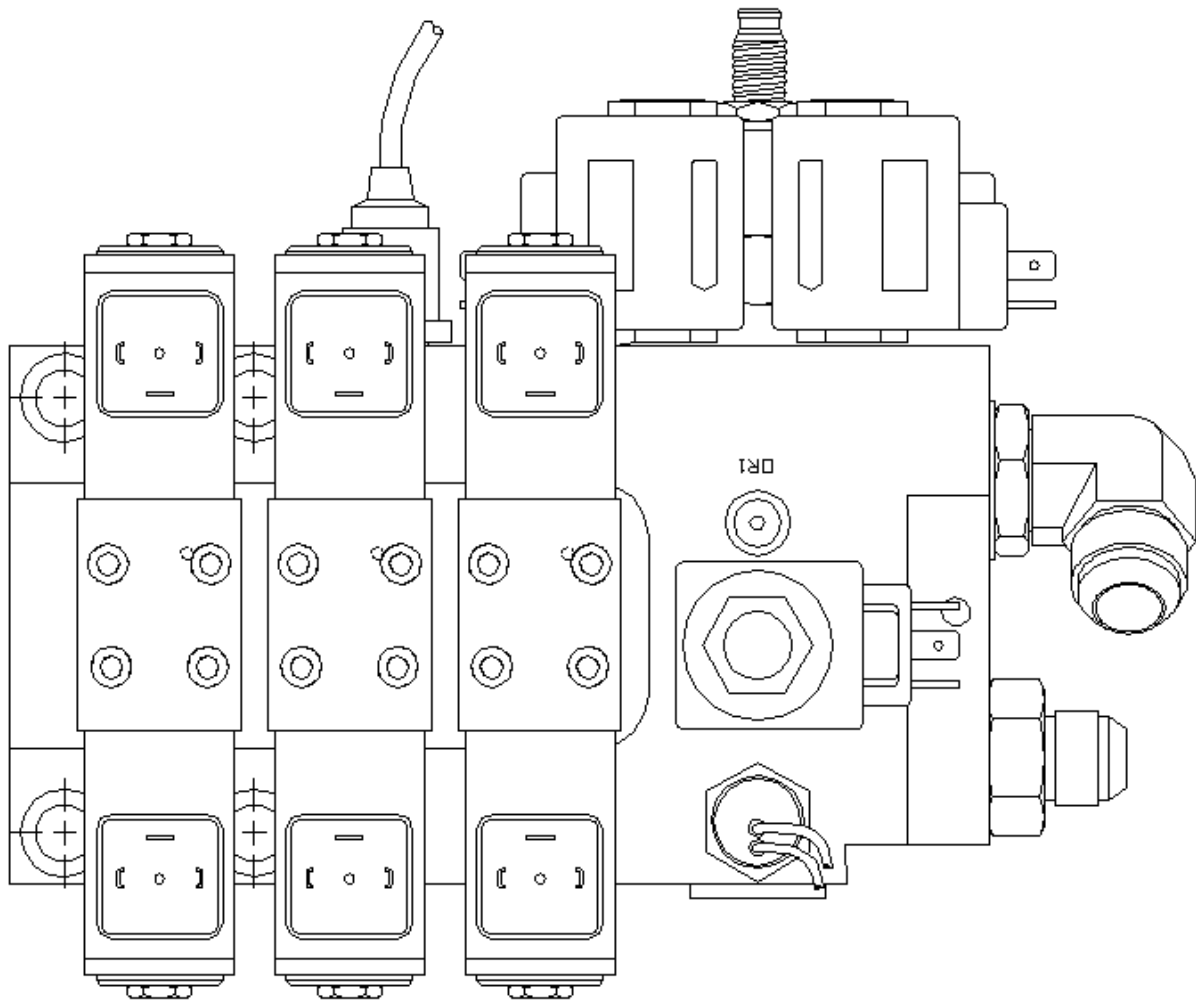

**Figure 2 ~ Hydraulic manifold assembly**

**Directional Valves:**

The directional valves (83222-6) are solenoid operated 4-way spool valves that are able to direct oil flow as required to rotate the hydraulic actuator to either open or close the gatebox doors.

The control system controls the three valves as required to maintain door position during operation of the system.

<b>Trotter Controls, Inc.</b> <b>FT. WORTH, TEXAS</b>	<b>TECHNICAL PAPER</b>		NUMBER <b>1002</b>
	<b>REPORT ORDER</b>	<input checked="" type="checkbox"/>	MODEL Fire Bombers
TITLE GEN II FRDS - SYSTEM DESCRIPTION	BY V. Trotter	CHK'D CG	SERIAL ALL FIREBOMBERS
	DATE 2/19/2009		PAGE <b>12</b> OF <b>30</b>

Note that the speed and direction of the rotary actuator is controlled by these directional valves.

Rotary Actuator:

The rotary actuator (83056-12) is a single vane unit with a maximum of 280 degrees of travel. The unit produces rotary motion where the angular velocity is proportional to the flow into the actuator and the torque is proportional to the differential pressure across the actuator ports.

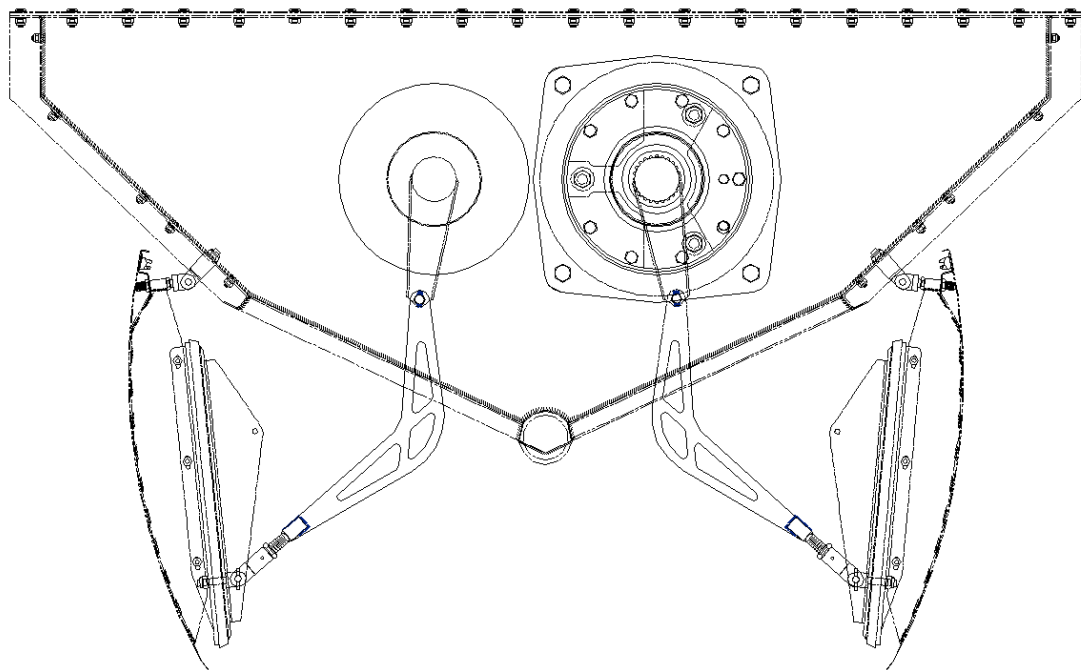

**Figure 3 ~ Hopper gatebox and doors controlled by the actuator**

The rotary actuator is used to open and close the gatebox doors shown in **Figure 3** and receives oil flow as dictated by the directional 4-way hydraulic valves (83222-6).

<b>Trotter Controls, Inc. FT. WORTH, TEXAS</b>	<b>TECHNICAL PAPER</b>		NUMBER <b>1002</b>
	<b>REPORT ORDER</b>	<input checked="" type="checkbox"/>	MODEL Fire Bombers
TITLE GEN II FRDS - SYSTEM DESCRIPTION	BY V. Trotter	CHK'D CG	SERIAL ALL FIREBOMBERS
	DATE 2/19/2009		PAGE 13 OF 30

Bleed Solenoid:

The bleed solenoid (83222-3) is a cartridge type normally open solenoid valve. It has a flow rating of 20 GPM at 200 PSI drop but the flow through this valve is limited by the 83222-22 orifice.

The normally open bleed solenoid (83222-3) is used to vent system pressure when system power is turned off. The solenoid is energized and held closed when system power is applied. Upon loss of power, the solenoid will open and allow system pressure to relieve into the vented reservoir. This avoids holding high pressure in the system when the system is not in use and automatically dumps system pressure when an emergency dump is initiated.

Emergency Dump Solenoids:

The two emergency dump solenoids (83222-3) are cartridge type normally open solenoid valves. Each valve has a 14 GPM rating at a pressure drop of 100 PSI, or 20 GPM at 200 PSI drop.

Note that these two valves are plumbed in parallel for redundancy.

**V. EMERGENCY DUMP SYSTEM:**

Emergency Dump (EDUMP) System Overview:

And independent, fully mechanical pneumatic system is implemented so that the doors can be opened in the event of a failure in the electrical or hydraulic systems. See Reference [5] for a fault tree analysis of the pneumatic EDUMP system and its effect on hazard minimization.

When power is off to the hydraulic system in normal operation, a mechanical four-bar, over centered toggle linkage arrangement is used to latch the doors closed as shown in Figure 4.

<b>Trotter Controls, Inc.</b> <b>FT. WORTH, TEXAS</b>		<b>TECHNICAL PAPER</b>		NUMBER <b>1002</b>	
		<b>REPORT ORDER</b>		<input checked="" type="checkbox"/>	
TITLE GEN II FRDS - SYSTEM DESCRIPTION		BY <b>V. Trotter</b>		MODEL Fire Bombers	
		CHK'D <b>CG</b>		SERIAL ALL FIREBOMBERS	
		DATE 2/19/2009		PAGE <b>14</b> OF <b>30</b>	

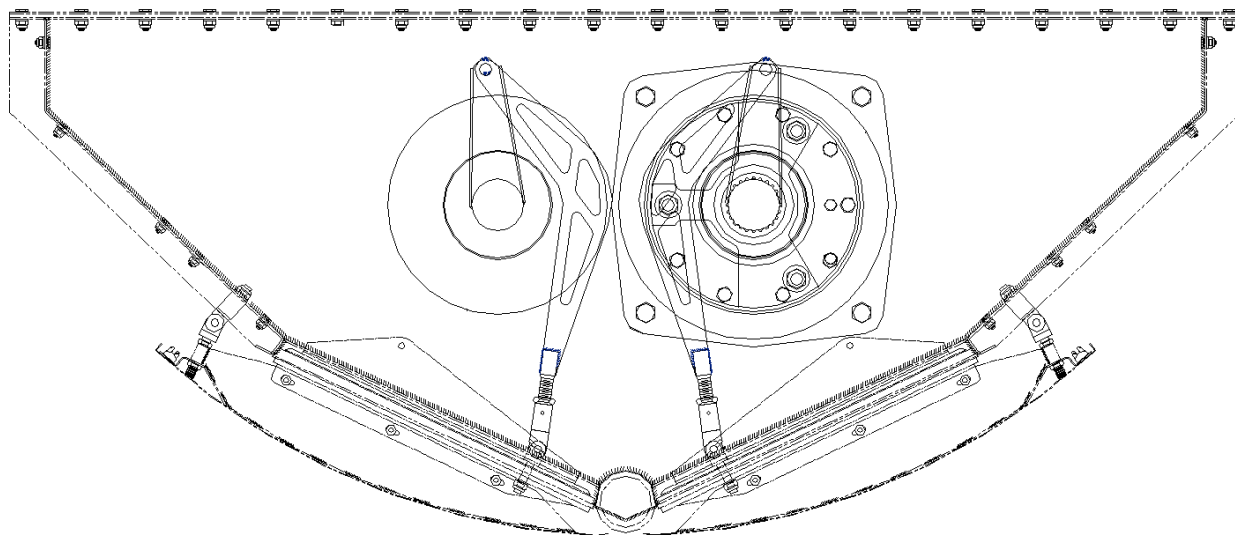

**Figure 4 ~ Gatebox doors shown in closed, over-centered and "latched" position**

To open the doors using the pneumatic EDUMP system, the pilot pushes the emergency dump handle forward causing the mechanical pneumatic system to open the gatebox doors past the over-center latched position.

The emergency dump system will function even if electrical power to the FRDS system is lost. The logic used for the emergency dump system is hardwired into the system using limit switches, solenoids, etc. as discussed below.

This system has been in use for many years on the AT802 and has proven to be reliable and virtually trouble free.

<b>Trotter Controls, Inc. FT. WORTH, TEXAS</b>	<b>TECHNICAL PAPER</b>		NUMBER <b>1002</b>
	<b>REPORT ORDER</b>	<input checked="" type="checkbox"/>	MODEL Fire Bombers
TITLE GEN II FRDS - SYSTEM DESCRIPTION	BY V. Trotter	CHK'D CG	SERIAL ALL FIREBOMBERS
	DATE 2/19/2009		PAGE 15
			OF 30

Please refer to the following reference materials when reviewing the following sections:

- Drawing 71060, sheet 2 for a schematic of the pneumatic EDUMP system
- Drawing 60441, sheet 21 for the electrical connection of the EDUMP limit switches
- Drawing 71807, sheet 2 for details on the installation of the pneumatic EDUMP system
- Attachment 1 for an overview diagram representing the FRDS system

Hydraulic Valves (FRDS related):

Upon loss of voltage to the system, all hydraulic valves used in the FRDS hydraulic system shift to the default emergency dump positions due to the type of solenoid valves selected. All valves shift to remove all pressure from the system.

Pneumatic Pressure Source:

The pneumatic pressure used for opening the gatebox door is provided by a pneumatic accumulator 71807-55 that is continuously charged with air pressure via turbine engine bleed air. This pressure is maintained in the accumulator via the 71807-40 check valve and the pressure in the tank is displayed on a mechanical gage in the cockpit.

EDUMP Lever and Limit Switches:

The 80866-1 handle assembly shown in Reference [11] is used by the pilot to initiate an emergency dump. The handle is connected to a 4 way pneumatic valve as well as two series connected limit switches (80866-25) shown installed in drawing 71807, Reference [10].

<b>Trotter Controls, Inc. FT. WORTH, TEXAS</b>	<b>TECHNICAL PAPER</b>		NUMBER <b>1002</b>
	<b>REPORT ORDER</b>		MODEL Fire Bombers
TITLE GEN II FRDS - SYSTEM DESCRIPTION	BY V. Trotter	CHK'D CG	SERIAL ALL FIREBOMBERS
	DATE 2/19/2009		PAGE 16
			OF 30

Air Switch (valve) and Pneumatic Cylinder:

When the emergency dump handle is pushed forward, the limit switches are opened and the 71807-71 pneumatic valve is shifted to extend the 71807-76 emergency dump pneumatic actuator.

Pneumatic EDUMP Operation Summary:

In summary, when the emergency dump handle is pushed forward by the pilot, the following events occur in sequential fashion:

- Power is turned off to the FRDS hydraulic system
  - The directional solenoid valves (83222-6) are closed to shut off the hydraulic oil supply to rotary actuator
  - The bleed solenoid (83222-3) is opened to bleed system pressure back to the reservoir
  - The two parallel connected emergency dump solenoids (83222-3) are opened
    - Opening the emergency dump solenoid allows the rotary actuator to freewheel (i.e. the actuator can be mechanically rotated over the toggle position with the emergency release lever)
    - Note that if the bleed solenoid valve were to fail, the emergency dump solenoid valves would dump any pressure coming through the directional valves (should be closed with power off) directly back to the low pressure fluid reservoir
- Air pressure is applied to the pneumatic EDUMP cylinder
- The pneumatic EDUMP cylinder extends, opening the gatebox doors.

**Trotter Controls, Inc.**  
**FT. WORTH, TEXAS**

**TECHNICAL PAPER**

NUMBER  
**1002**

**REPORT  
ORDER**

MODEL  
Fire Bombers

TITLE  
GEN II FRDS - SYSTEM DESCRIPTION

BY  
V. Trotter

CHK'D  
CG

SERIAL  
ALL FIREBOMBERS

DATE  
2/19/2009

PAGE  
17

OF  
30

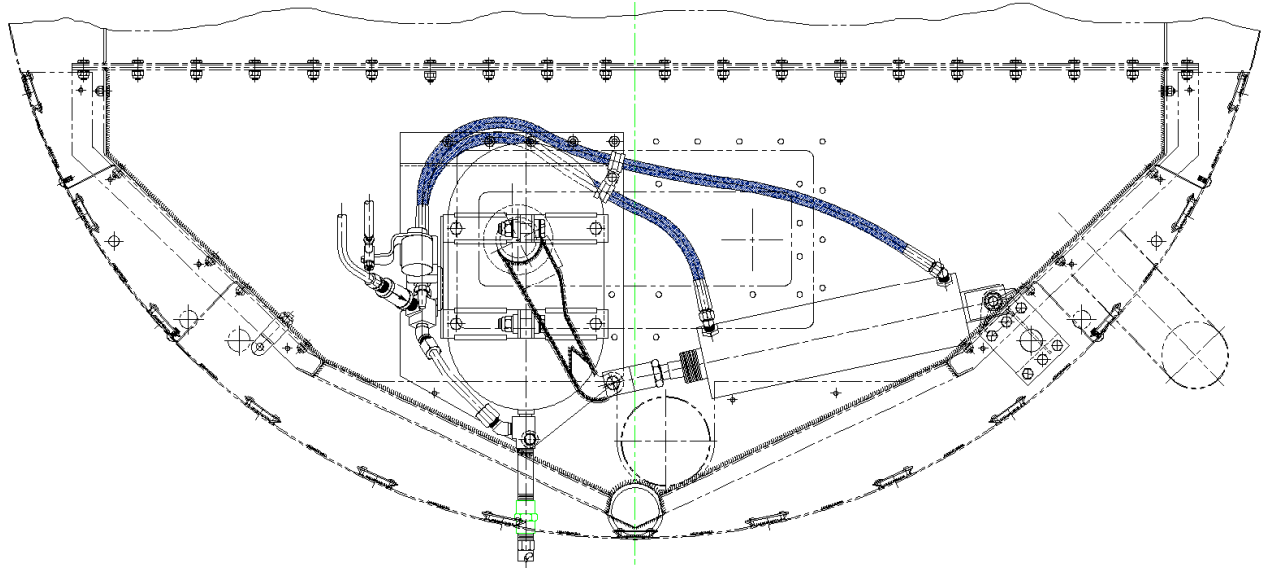

**Figure 5 ~ Pneumatic EDUMP accumulator, cylinder, hoses, and other components shown mounted to the aft end of the gatebox.**

<b>Trotter Controls, Inc.</b> <b>FT. WORTH, TEXAS</b>	<b>TECHNICAL PAPER</b>		NUMBER <b>1002</b>
	<b>REPORT ORDER</b>		MODEL Fire Bombers
TITLE GEN II FRDS - SYSTEM DESCRIPTION	BY V. Trotter	CHK'D CG	SERIAL ALL FIREBOMBERS
	DATE 2/19/2009		PAGE OF 18 30

**VI. SUMMARY OF OPERATION:**

The system operates as described below (please refer to the Hydraulic System Schematic, drawing 80504):

**Pilot Interface Operation:**

The pilot interface is used to interact with the pilot and allow the pilot control of all FRDS function. The functions of the various switches on the pilot interface are described in the following sections along with descriptions of the items displayed.

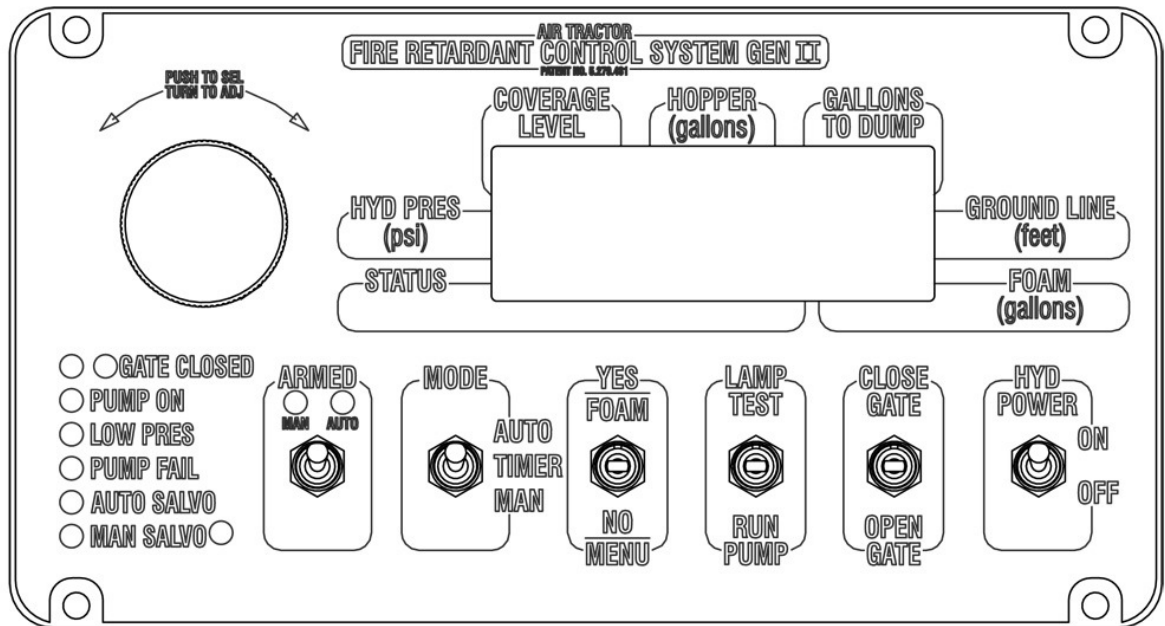

**Figure 6 ~ Generation 2 Pilot Interface**

<b>Trotter Controls, Inc. FT. WORTH, TEXAS</b>	<b>TECHNICAL PAPER</b>		NUMBER <b>1002</b>
	<b>REPORT ORDER</b>		MODEL
TITLE GEN II FRDS - SYSTEM DESCRIPTION	BY	CHK'D	Fire Bombers
	V. Trotter	CG	SERIAL
	DATE	2/19/2009	ALL FIREBOMBERS
			PAGE <b>OF</b>
		19	30

Modes of Operation:

There are several modes of operation for the system. The operation mode is selected using the mode switch on the pilot interface. The various modes for the system are shown below.

**Table 1 ~ FRDS Operation Modes during normal operation**

Power Sw	Armed Sw	Mode Sw	System State / Mode
OFF	X	X	Display Active, No pressure available to hydraulics, no pressure in system
ON	OFF	X	Display active, pressure available to hydraulics, no power available to valves to cause actuator motion, pressing dump switch has no effect
ON	ON	AUTO	Automatic control, power to hydraulics, depressing dump switch initiates delivery <ul style="list-style-type: none"> <li>• Constant flow rate</li> <li>• Microprocessor Auto Salvo and Electro-mechanical Auto Salvo Active</li> </ul>
ON	ON	TIMER	Timer based control of doors, power to hydraulics, depressing dump switch initiates delivery <ul style="list-style-type: none"> <li>• Microprocessor Auto Salvo and Electro-Mechanical Auto Salvo Active</li> <li>• No sensors except pressure sensor required for operation</li> </ul>
ON	ON	EM	Electro-mechanical control, power to hydraulics, depressing dump switch initiates delivery <ul style="list-style-type: none"> <li>• Electro-Mechanical Auto Salvo Active Only</li> <li>• Pressure Switch Controls Pump</li> <li>• Doors @ full open or full close only</li> </ul>

<b>Trotter Controls, Inc. FT. WORTH, TEXAS</b>	<b>TECHNICAL PAPER</b>		NUMBER <b>1002</b>
	<b>REPORT ORDER</b>		MODEL Fire Bombers
TITLE GEN II FRDS - SYSTEM DESCRIPTION	BY V. Trotter	CHK'D CG	SERIAL ALL FIREBOMBERS
	DATE 2/19/2009		PAGE OF
			20                      30

Automatic Mode:

The table below shows the functionality of the pilot interface switches when in AUTO mode.

**Table 2 ~ Pilot interface switch functions when in AUTO mode.**

Parameter	Device Type	Action	Comments
Hyd Power	Switch	Turns on hydraulic power	Energize EDUMP valves, BLEED valve, pressurize hydraulic system
Dump Switch	Switch - 1NO, 1NC	Open the doors when pressed, Close doors when released	Located on flight stick
Armed Sw	Switch	Arms hydraulic system directional valves (hardware), turn armed lamp on if real time diagnostics OK	Display Armed & Ready on Status, Light LED if all is ready
Mode Switch	Auto, Timer, EM Switch	Set Mode: Auto, Timer, or EM	Display the current mode to the pilot
Open Door Sw	Switch	Open the doors at 1/8 speed, Display: Open doors switch on, opening door	Open doors manually using the primary system
Close Door Sw	Switch	Close the doors at 1/8 speed, Display: Close doors switch on, closing door	Close doors manually using the primary system
Run Pump Sw	Switch	Turn on pump output, Display: Run pump switch on, running pump	Run the pump using the primary system
Test Lamps Sw	Switch	Test all lamps that can be tested	
Yes Sw / No Sw	Switch	Not used for normal operation	Used for menu selection
Coverage Level (Delivery Parameter)	Data Wheel	(AT1002) 0.5, 1, 2, 3, 4, 5, 6, Max	Set the retardant flow rate desired
Gals to Dump (Delivery Parameter)	Data Wheel	(AT1002) Pilot, 250, 330, 500, ALL	Gals to dump display limited by amount in the tank

<b>Trotter Controls, Inc. FT. WORTH, TEXAS</b>	<b>TECHNICAL PAPER</b>		NUMBER <b>1002</b>
	<b>REPORT ORDER</b>		MODEL
TITLE GEN II FRDS - SYSTEM DESCRIPTION	BY	CHK'D	Fire Bombers
	V. Trotter	CG	SERIAL
	DATE	2/19/2009	ALL FIREBOMBERS
			PAGE <b>OF</b>
			21 30

The items shown Table 3 are displayed to the pilot during normal operation.

**Table 3 ~ Items displayed to pilot in during normal (AUTO) operation**

Parameter	Values Displayed To Pilot	Comments
Coverage Level	(AT1002) 0.5, 1, 2, 3, 4, 5, 6, Max (only displayed in AUTO mode)	This is a pilot input
Gals to Dump	(AT1002) Pilot, 250, 330, 500, ALL (only displayed in AUTO mode)	This is a pilot input ~ Gals to dump display is limited by the amount of fluid in the hopper
Gals in Hopper	0-1100 (AT1002)	Actual gallons in hopper
Ground Line	0 ~ 3262 Feet (only displayed in AUTO mode)	Distance covered by the delivery on the ground
Hydraulic Pressure	0-4000 PSI	Actual maximum pressure is 3000 PSI.
Status	Various test messages	Status of system to pilot.
Status LED's		
Gate Closed 1	Gatebox doors open	Prox used in Auto mode and by uP Auto Salvo System
Gate Closed 2	Gatebox doors open	Prox used in Auto mode and by EM Auto Salvo System
Pump running	Hyd. Pump is active	The pump relay is on
Low Press	Hyd. Pressure < 2600 PSI	
Pump Fail	Pump failed to pressurize system as expected	An error condition
Auto Salvo	The uP Auto Salvo System was activated	An error condition
EM Salvo	The EM Auto Salvo System was activated	An error condition

<b>Trotter Controls, Inc.</b> <b>FT. WORTH, TEXAS</b>	<b>TECHNICAL PAPER</b>		NUMBER <b>1002</b>
	<b>REPORT ORDER</b>	<input checked="" type="checkbox"/>	MODEL Fire Bombers
TITLE GEN II FRDS - SYSTEM DESCRIPTION	BY V. Trotter	CHK'D CG	SERIAL ALL FIREBOMBERS
	DATE 2/19/2009		PAGE <b>OF</b> 22 30

Electro-Mechanical Mode:

The table below shows the functionality of the pilot interface switches when in Electro-Mechanical (EM) mode.

**Table 4 ~ Pilot interface switch functions when in EM mode.**

Mode	Pilot Interface / Switch	Action	Affected valve(s)
EM	Turns on hydraulic power	Activate pump to pressurize hydraulic system	Energize EDUMP valves, BLEED valve
EM	Armed Switch	Arms hydraulic system (hardware), turn armed lamp on	
EM	Open Door Switch	Open Doors @ 1/8 speed	Valve 3, Open Coil
EM	Close Door Switch	Close doors @ 1/8 speed	Valve 3, Close
EM	Dump Trigger (located on flight stick)	Open doors when pressed, close doors when released	Valve 3, Open Valve 3, Close
EM	Run Pump Switch	Turn on pump output, Display: Run pump switch on, running pump	Run the pump using the primary system
EM	Mode Switch - Set to EM	Maintain Pressure	Bleed Solenoid - Valve Closed
EM	Mode Switch - Set to EM	Maintain isolation between actuator ports	EDUMP1 - Valve Closed
EM	Mode Switch - Set to EM	Maintain isolation between actuator ports	EDUMP2 - Valve Closed
EM	Mode Switch - Set to EM	Pump controlled by EM system	Pump controlled directly by pressure switch

<b>Trotter Controls, Inc. FT. WORTH, TEXAS</b>	<b>TECHNICAL PAPER</b>		NUMBER <b>1002</b>
	<b>REPORT ORDER</b>	<input checked="" type="checkbox"/>	MODEL Fire Bombers
TITLE GEN II FRDS - SYSTEM DESCRIPTION	BY V. Trotter	CHK'D CG	SERIAL ALL FIREBOMBERS
	DATE 2/19/2009		PAGE 23
			OF 30

System Power Off State:

1. When system power is turned off, the directional solenoid valves remain closed, the emergency dump solenoid opens (allowing free flow between the ports of the actuator in one direction), and the bleed solenoid opens (venting the system pressure back to the reservoir).
2. The doors are held closed by a mechanical over-center toggle arrangement shown in Figure 4 on page 14.

Automatic Operation: (primary system - microprocessor control)

1. Master power from the aircraft bus is turned on to the system.
  - a. The normally open emergency dump and bleed solenoid (83222-3) close (allow no flow) and remain closed as long as power is on to the system.
  - b. The normally closed directional valves (83222-6) remain closed.
  - c. The system microprocessor boots and displays hydraulic pressure and other parameters to the pilot and monitors sensors, etc.
2. The hydraulic switch on the pilot interface is turned on
  - a. The bleed solenoid valve and emergency dump solenoid valves are energized.
  - b. The hydraulic pump (80577-60) comes on and starts charging the nitrogen filled accumulators (80577-61) (if the hydraulic pressure is less than 2750 PSI the pump is activated; if the pressure is greater than 3000 PSI the pump turns off).
  - c. The microprocessor system passively monitors for loose wires, burned out solenoid valves, voltages, and other items.
  - d. The pilot can run a quick diagnostic where all functions that do not cause door movement are tested, or a full diagnostic where all valves and door movement is verified (system must be armed).
3. If the doors are not closed, the pilot can close the doors manually only if the system is armed.

<b>Trotter Controls, Inc. FT. WORTH, TEXAS</b>	<b>TECHNICAL PAPER</b>		NUMBER <b>1002</b>
	<b>REPORT ORDER</b>		MODEL
TITLE GEN II FRDS - SYSTEM DESCRIPTION	BY	CHK'D	Fire Bombers
	V. Trotter	CG	SERIAL
	DATE	2/19/2009	ALL FIREBOMBERS
			PAGE <b>24</b> OF <b>30</b>

4. The hydraulic pressure reaches 3000 PSI and the pump turns off.
5. Since the directional valves are closed, there is no leakage flow through the system and the pump remains off.
6. The system is now in standby mode and ready to operate using the high pressure hydraulic oil stored in the nitrogen accumulators. However, no power is available to the directional valves needed to operate the gatebox doors until the system is armed using the ARM switch.
7. To operate the system, the pilot inputs amount of retardant to deliver (GALS TO DUMP), and the flow rate desired (COVERAGE LEVEL). These inputs determine how fast the doors will open and the length of time that they will stay open. A typical release takes from 0.5 second to 10 seconds to complete.
8. The pilot arms the system by turning on the locking arm switch on the pilot interface and then initiates a release by pressing the fire button located on the control stick handle.
9. The directional solenoid valves open allowing the accumulator to supply oil flow to the rotary actuator.
10. The three directional valves are controlled as required to maintain the door angle needed to maintain constant liquid flow rate as the gallons in the hopper and aircraft acceleration vary.
11. When the hydraulic pressure drops to 2750 PSI, the hydraulic pump is activated and begins to provide oil flow at approximately 0.71~0.83 GPM and runs until the system pressure reaches 3000 PSI.
12. When the correct amount of retardant has been delivered, the doors are closed thus cutting off the flow of retardant.
13. As soon as the doors are closed, the directional solenoid valves close.
14. When the hydraulic pressure reaches 3000 PSI, the hydraulic pump will turn off.
15. The system is in now in standby mode and ready for another delivery cycle.

<b>Trotter Controls, Inc. FT. WORTH, TEXAS</b>	<b>TECHNICAL PAPER</b>		NUMBER <b>1002</b>
	<b>REPORT ORDER</b>	<input checked="" type="checkbox"/>	MODEL Fire Bombers
TITLE GEN II FRDS - SYSTEM DESCRIPTION	BY V. Trotter	CHK'D CG	SERIAL ALL FIREBOMBERS
	DATE 2/19/2009		PAGE 25
			OF 30

Electro-Mechanical Operation:

The system includes a secondary electro-mechanical system that uses only relays and two timers to control the system (no sensors except the pressure switch). This system uses only one directional valve and moves the doors at relatively low speed. The position of the doors is not controlled, and the doors can move to the fully open or the fully closed positions only.

Operation is identical to that of the automatic system described above with the following differences:

1. The hydraulic pump relay is controlled directly by the pressure switch.
2. Door position is fully open or fully closed only.
3. Only a single directional valve is used so the maximum door speed is approximately 1/8<sup>th</sup> the fastest door speed achievable with the automatic system.
4. The AUTO SALVO system is active, but the redundancy is reduced since only the electro-mechanical AUTO SALVO system is active (the entire microprocessor system is bypassed).
5. The micro-processor primary system performs monitor and display functions only.

Auto Salvo System:

The FRDS AUTO SALVO system monitors the position of the gatebox doors and opens the doors if they fail to open as expected.

The FRDS system utilizes two independent AUTO SALVO systems to provide increased reliability. These systems are electrically isolated from the primary system and receive their power independently.

- Microprocessor (µP) Auto Salvo System ~ This system utilizes a very simple secondary microprocessor to monitor the gatebox doors. If the doors do not open within approximately 0.8 seconds when expected to open, the primary auto system is isolated and the doors are opened by the µP Auto Salvo

<b>Trotter Controls, Inc. FT. WORTH, TEXAS</b>	<b>TECHNICAL PAPER</b>		NUMBER <b>1002</b>
	<b>REPORT ORDER</b>		MODEL Fire Bombers
TITLE GEN II FRDS - SYSTEM DESCRIPTION	BY V. Trotter	CHK'D CG	SERIAL ALL FIREBOMBERS
	DATE 2/19/2009		PAGE 26
			OF 30

System. Note that this system is only active when in AUTO or Timer mode (not active for EM mode).

- Electro-Mechanical (EM) Auto Salvo System ~ This system utilizes relays and timers to monitor the doors. If the doors do not open within 1.5 seconds when expected to open, the primary auto system AND the ( $\mu$ P) Auto Salvo System are isolated and the doors are opened by the EM Auto Salvo System. This system has no software.

The hardware utilized for the AUTO SALVO systems is briefly described in Table 5.

<b>Trotter Controls, Inc.</b> <b>FT. WORTH, TEXAS</b>	<b>TECHNICAL PAPER</b>		NUMBER <b>1002</b>
	<b>REPORT ORDER</b>	<input checked="" type="checkbox"/>	MODEL Fire Bombers
TITLE GEN II FRDS - SYSTEM DESCRIPTION	BY V. Trotter	CHK'D CG	SERIAL ALL FIREBOMBERS
	DATE 2/19/2009		PAGE 27
			OF 30

**Table 5 ~ Components related to the  $\mu$ P Auto Salvo System.**

System	Component	Device Type	Expected State	Comments
$\mu$ P Based Auto Salvo System				Only Active in AUTO or Timer Mode
	Secondary Microprocessor ( $\mu$ P)	Logic	Doors must open in 0.8 seconds after Dump Switch pressed	Secondary microprocessor for Auto Salvo Function only - Only Active in AUTO or Timer Mode
	Power On Switch	Input	ON	Enables power to hydraulics and Auto Salvo Systems
	Armed Switch	Input	ARMED	Enables Auto Salvo System
	Dump Switch	Input	ON $\uparrow$	Trigger to start monitoring doors closed
	Gatebox Doors Closed #1	Input	ON - Doors closed, OFF - Doors Open	Primary Door Closed Sensor
	Directional Valve #2 - Door Open	Output / Control Element		Controlled by $\mu$ P Auto System
	Bleed and EDUMP solenoids	Output / Control Element		Controlled by $\mu$ P Auto System
	Directional Valves #1, #3	Isolated	Isolated	Isolated
	Isolation Relay(s)	Output / Control Element		Disconnects auto system
	$\mu$ P Auto Salvo LED	Output / Pilot Status		Alerts pilot of $\mu$ P AUTO SALVO condition

Notes:

1. This system is not active when the system is set to EM mode.

<b>Trotter Controls, Inc.</b> <b>FT. WORTH, TEXAS</b>	<b>TECHNICAL PAPER</b>		NUMBER <b>1002</b>
	<b>REPORT ORDER</b>	<input checked="" type="checkbox"/>	MODEL Fire Bombers
TITLE GEN II FRDS - SYSTEM DESCRIPTION	BY V. Trotter	CHK'D CG	SERIAL ALL FIREBOMBERS
	DATE 2/19/2009		PAGE OF 28                      30

**Table 6 ~ Components related to the EM Auto Salvo System.**

System	Component	Device Type	Expected State	Comments
Electro-Mechanical Auto Salvo System				Active in all modes when power is on and system ARMED
	EM Auto Salvo Relays and Timers	Logic	Doors must open in 1.4 seconds after PWR ON, ARMED, and Dump Switch pressed	Hardwired Logic - Not software
	Power On Switch	Input	ON	Enable power to hydraulics and Auto Salvo System
	Armed Switch	Input	ARMED	Enables Auto Salvo System Monitoring
	Dump Switch	Input	ON	Trigger to start monitoring doors closed
	Gatebox Doors Closed Sensor #2	Input	ON - Doors closed, OFF - Doors Open	Secondary doors closed sensor
	Directional Valve #3 - Door Open	Output / Control Element		Controlled by EM Auto Salvo System
	Bleed and EDUMP solenoids	Output / Control Element		Controlled by EM Auto Salvo System
	Directional Valves #1, #3	Isolated	Isolated	Isolated
	Isolation Relay(s)	Output / Control Element		Disconnects Auto System and $\mu$ P Auto Salvo System
	EM Auto Salvo LED	Output / Pilot Status		Alerts pilot of EM AUTO SALVO condition

**Notes:**

1. This system is active in all operation modes. There is loss of redundancy in EM mode since the  $\mu$ P Auto Salvo is not active and the EM Auto Salvo uses the same hydraulic valve as is used for EM mode operation.

<b>Trotter Controls, Inc. FT. WORTH, TEXAS</b>	<b>TECHNICAL PAPER</b>		NUMBER <b>1002</b>
	<b>REPORT ORDER</b>	<input checked="" type="checkbox"/>	MODEL Fire Bombers
TITLE GEN II FRDS - SYSTEM DESCRIPTION	BY V. Trotter	CHK'D CG	SERIAL ALL FIREBOMBERS
	DATE 2/19/2009		PAGE OF
			29 30

Auto Salvo System Operation:

- Pre-conditions to "arm" the Auto Salvo System
  - Set the POWER switch to "ON"
  - Set the ARM switch to "ON"
  - Auto Salvo System(s) are enabled and monitoring the doors
  
- AUTO or TIMER Mode:
  - Set the Mode switch to "AUTO" or "TIMER"
  - The "DUMP" switch is depressed.
  - If the doors do not open (sensed by gatebox prox#1) within 0.8 seconds, the following occurs
    - µP Auto Salvo System energizes a relay to isolate the valves from the normal microprocessor control.
    - µP Auto Salvo System energizes the bleed solenoid valve, the EDUMP solenoid valve, runs the pump, and energizes directional valve #2 open solenoid coil.
    - The doors are opened using the hydraulic actuator
  - If the doors do not open (sensed by gatebox prox#2) within 1.5 seconds, the following occurs
    - EM Auto Salvo System energizes a relay to isolate the valves from the normal microprocessor control and the µP Auto Salvo System.
    - EM Auto Salvo System energizes the bleed solenoid valve, the EDUMP solenoid valve, runs the pump, and energizes directional valve #3 open solenoid coil.
    - The doors are opened using the hydraulic actuator
  
- EM Mode:
  - Set the Mode switch to EM (Electro-Mechanical Mode)
  - The "DUMP" switch is depressed.
  - If the doors do not open (sensed by gatebox prox#2) within 1.5 seconds, the following occurs
    - EM Auto Salvo System energizes a relay to isolate the valves from the normal microprocessor control and the µP Auto Salvo System.
    - EM Auto Salvo System energizes the bleed solenoid valve, the EDUMP solenoid valve, runs the pump, and energizes directional valve #3 open solenoid coil.

<b>Trotter Controls, Inc. FT. WORTH, TEXAS</b>	<b>TECHNICAL PAPER</b>		NUMBER <b>1002</b>
	<b>REPORT ORDER</b>	<input checked="" type="checkbox"/>	MODEL Fire Bombers
TITLE GEN II FRDS - SYSTEM DESCRIPTION	BY V. Trotter	CHK'D CG	SERIAL ALL FIREBOMBERS
	DATE 2/19/2009		PAGE 30
			OF 30

- The doors are opened using the hydraulic actuator

Door Position Control Loop Description:

Please refer to Attachment 2 when reviewing the items below.

The gatebox door position is controlled using closed loop feedback based on the sensed hydraulic actuator angle when the system is in AUTO mode only.

The position control of the doors is briefly described below:

- The POWER and ARM switches are set to "ON" or "ARMED"
- The MODE switch is set to "AUTO".
- The coverage level (flow rate) and gallons to dump is selected by the pilot.
- The dump switch is depressed.
- The "ideal" door angle needed to produce the requested flow rate is calculated.
- The actual door angle is compared to the sensed actual door angle. This calculation is performed every 0.002 seconds by the systems on-board digital signal processor.
- The directional valve is controlled by the microprocessor as required to make the actual door angle equal to the "ideal" calculated angle.
- When the "Ideal" and "Actual" door angles match within a predefined error band, the valves are turned off so that there is no quiescent flow through the valves.
  - If the error exceeds the pre-defined allowable error band, the directional valve will be activated as required to minimize this error.